

良機

1962創業

Cooling Tower

Series

R-LC

LIANG CHI INDUSTRY CO., LTD.

多功能冷却塔性能測試場
COOLING TOWER TEST LABORATORY PER CTI

Liang Chi Series R-LC cooling towers have been designed for cross flow type with Low Noise Motor and Fan. The compact design is suitable for Equipment Cooling, Industrial Process Cooling and Air Conditioning.



Thermal Performance certified by the Cooling Technology Institute (CTI) in accordance with CTI STD-201

Characteristics

Design of Integrated System

Liang chi low noise cross flow rectangular type of series R-LC cooling towers have been designed according to the international standards. The light weight structure and standardized components of R-LC tower feature easy transport, lifting and site installation.

Low Noise & Easy Maintenance

Series R-LC cooling tower use high tension V-belt reducers, which are corresponding to the low noise axial flow fans featuring silent operation and easy maintenance.

Light Weight, Less Space and Multi-Cell Installation

Comparing with other types of cooling tower, R-LC features lighter operational weight and less installation space. Also the combinative multi-cell structure is suitable for large cooling requirement and future expansion.

Unique Distribution System & Efficient Heat Exchange

Gravitational distribution systems features low pressure and slow water flow which can prolong cooling duration and ensure cooling efficiency.

Efficient Performance

Unique design of vacuum-formed & round-chorded filling with ripple surface facilitate even spread & long duration of water drop and free of deposits & scales.

Low Electrical Power Consumption

The high efficient hydrodynamic "venturi-tube" fan stack with high efficient low-resistance filling facilitates good ventilation and reduction of fan motor power to save electrical power.

Durableness & Low Maintenance Cost

R-LC tower components are made of weather-proof and anti-corrosive materials. Casing is in anti-ultraviolet P.V.C. which features sound -proof and non-decayed merits with fine stream-lined outlook. Fan stack, basin and access-door are made by F.R.P. Filling & inlet louvers are by P.V.C. Supporting rack is by light weight steel. All the steel parts are hot-dip-galvanized so as to enable the durableness and low cost.

Easy Piping Work & Low Installation Cost

All the piping connections are gathered on basin except inlet pipe connection which lies over the distribution basin for easy piping.

Structure and Standard Materials

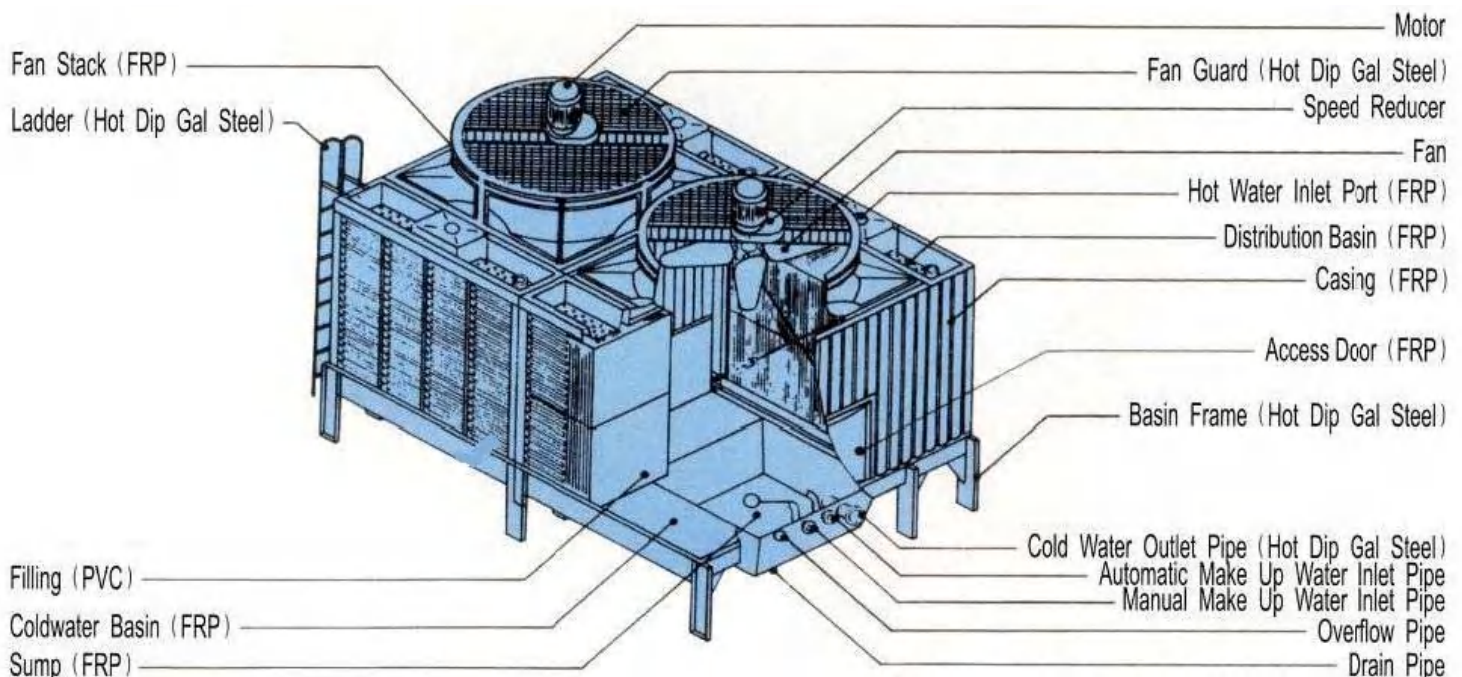

Recommended Concrete Foundations

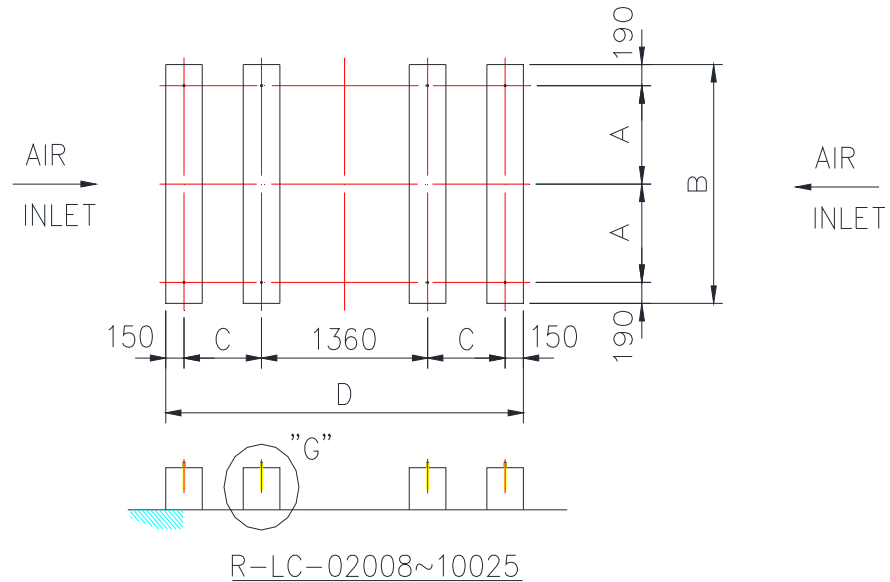
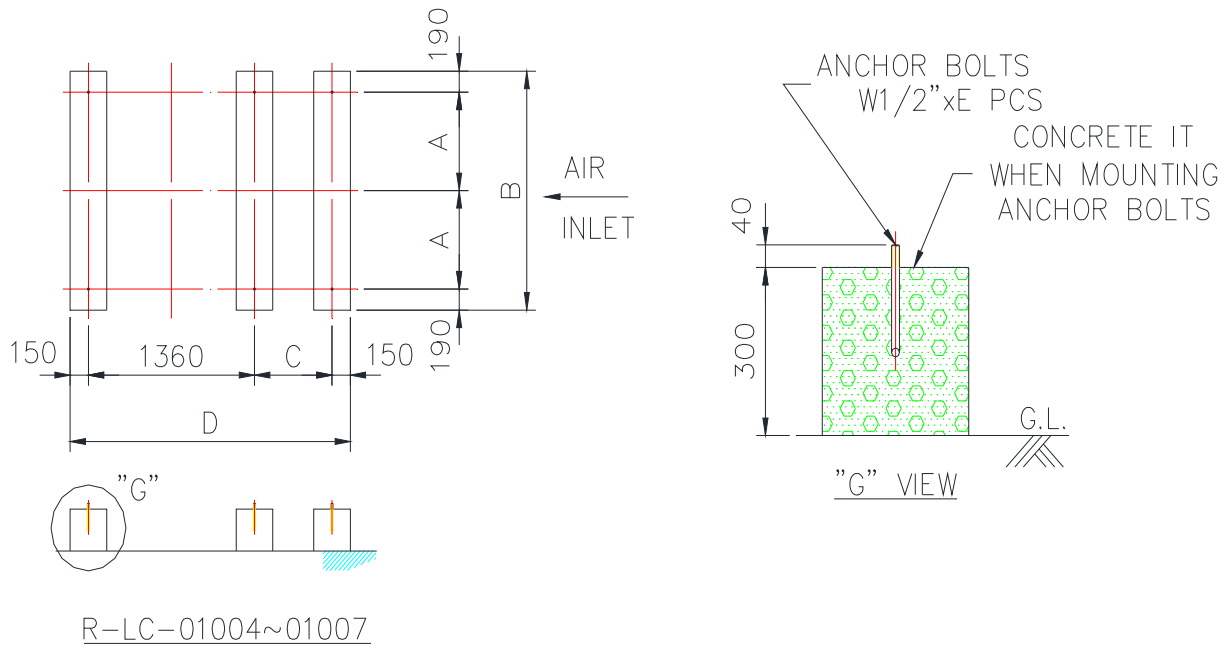

NOTES :

1. All concrete foundations must be level on the top.
2. The concrete foundations as shown are non-isolator type. For isolator type, please contact your local supplier or distributor.
3. Multiple cell models of the single cell models are also available but not showed. For more information, please contact your local supplier or distributor.
4. All dimensions are in millimeters.

R-LC-ITEMS	01004	01005	01006	01007	02008	02010	05012	05015	07017	07020	07022	10025
A	702.5	802.5	902.5	1002.5	702.5	802.5	902.5	1105	1105	1205	1255	1405
B	1785	1985	2185	2385	1785	1985	2185	2590	2590	2790	2890	3190
C	635	635	735	735	635	635	735	835	835	885	985	985
D	2295	2295	2395	2395	2930	2930	3130	3330	3330	3430	3630	3630
E	6	6	6	6	8	8	8	8	8	8	8	8

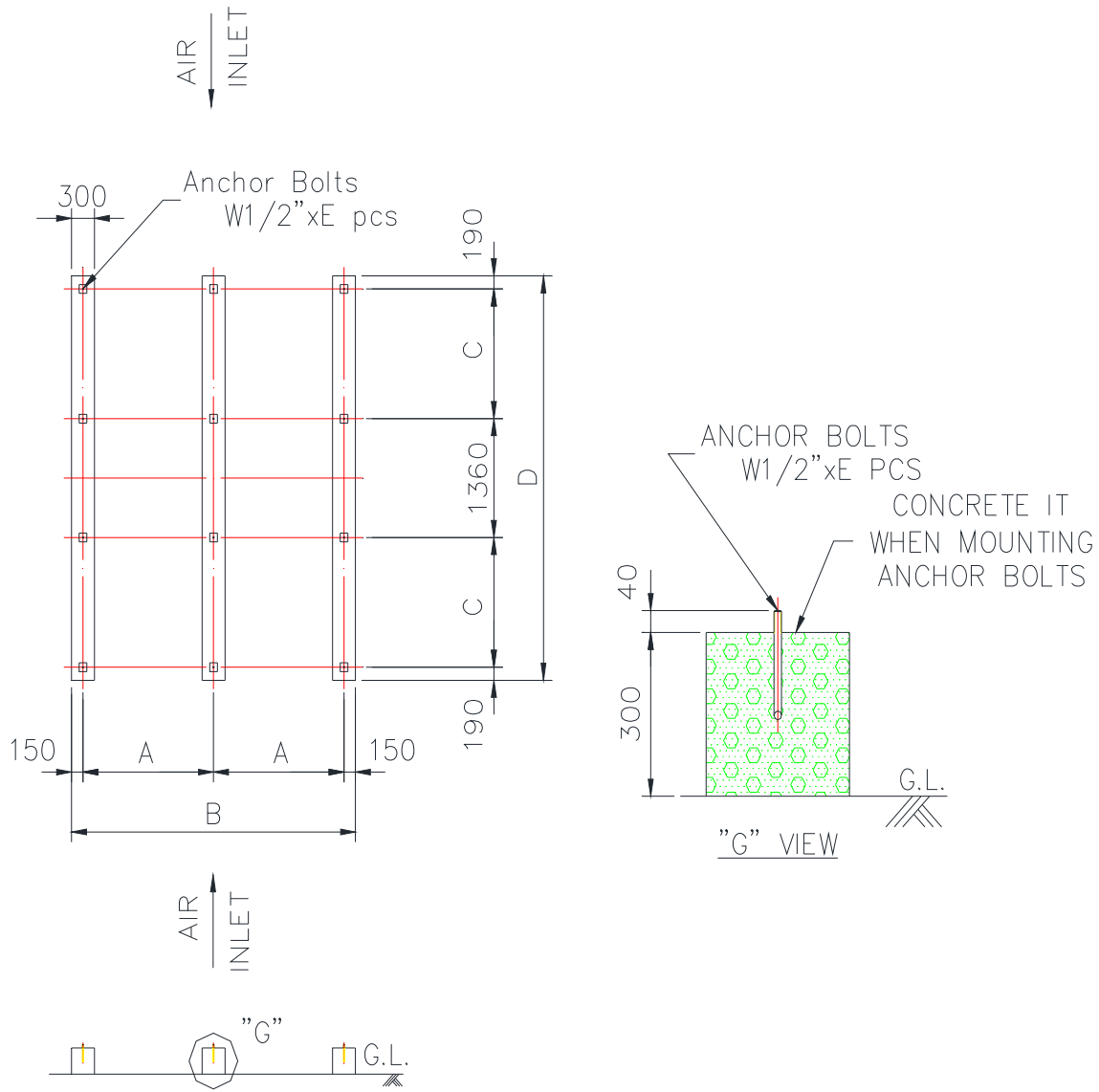

R-LC-10030~15050

NOTES:

1. All concrete foundations must be level on the top.
2. The concrete foundations as shown are non-isolator type. For isolator type, please contact your local supplier or distributor.
3. Multiple cell models of the single cell models are also available but not showed. For more information, please contact your local supplier or distributor.
4. All dimensions are in millimeters.

R-LC-ITEMS	10030	10035	15040	15045	15050
A	1710	1810	2010	2010	2110
B	3720	3920	4320	4320	4520
C	1485	1485	1685	1985	1985
D	4710	4710	5110	5710	5710
E	12	12	12	12	12

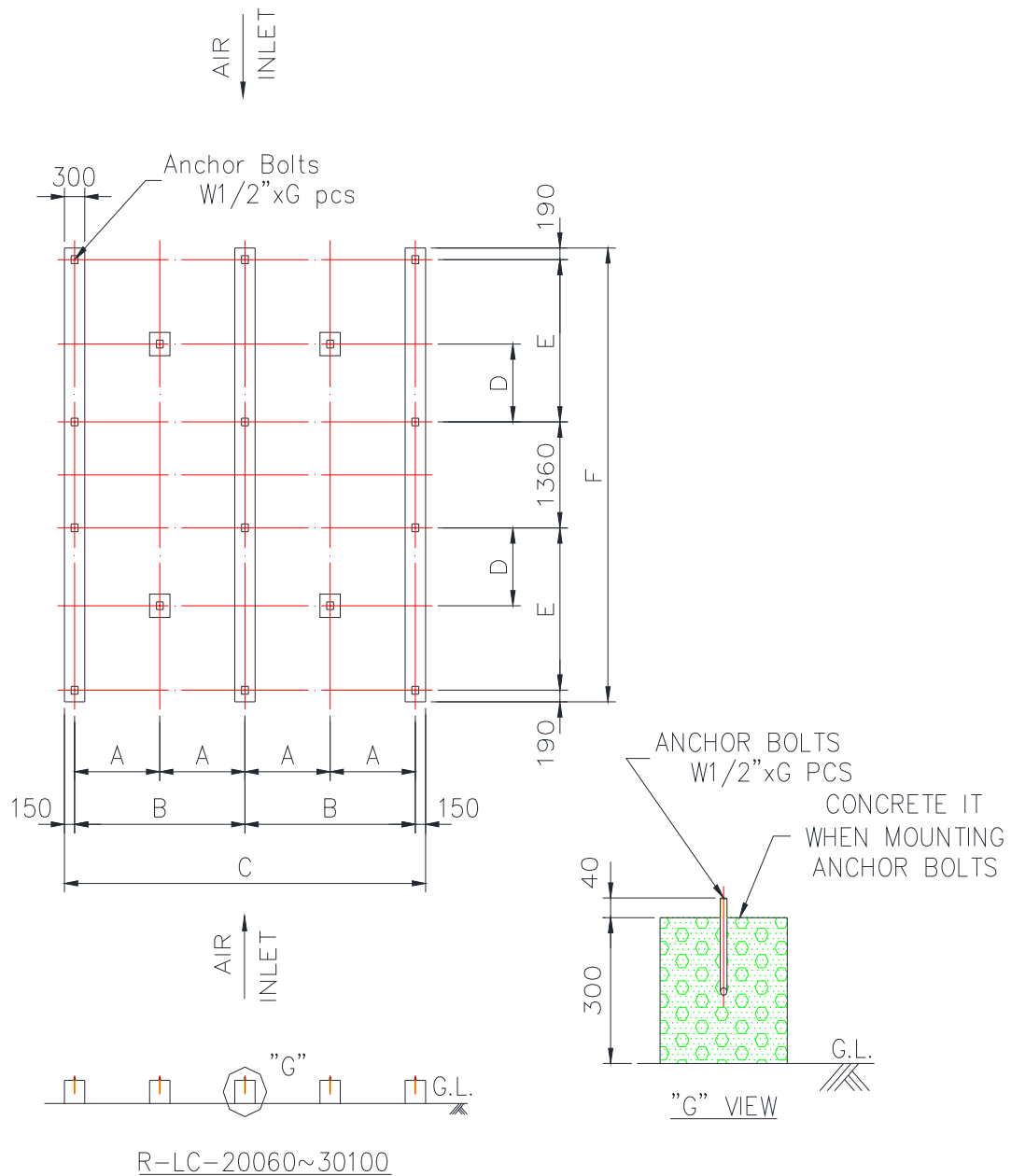

NOTES :

1. All concrete foundations must be level on the top.
2. The concrete foundations as shown are non-isolator type. For isolator type, please contact your local supplier or distributor.
3. Multiple cell models of the single cell models are also available but not showed. For more information, please contact your local supplier or distributor.
4. All dimensions are in millimeters.

R-LC-ITEMS	20060	20070	30080	30090	30100
A	1255	1405	1405	1555	1755
B	2510	2810	2810	3110	3510
C	5320	5920	5920	6520	7320
D	1000	1000	1175	1175	1175
E	2085	2085	2435	2435	2435
F	5910	5910	6610	6610	6610
G	16	16	16	16	16

Dimensions and Standard Specifications

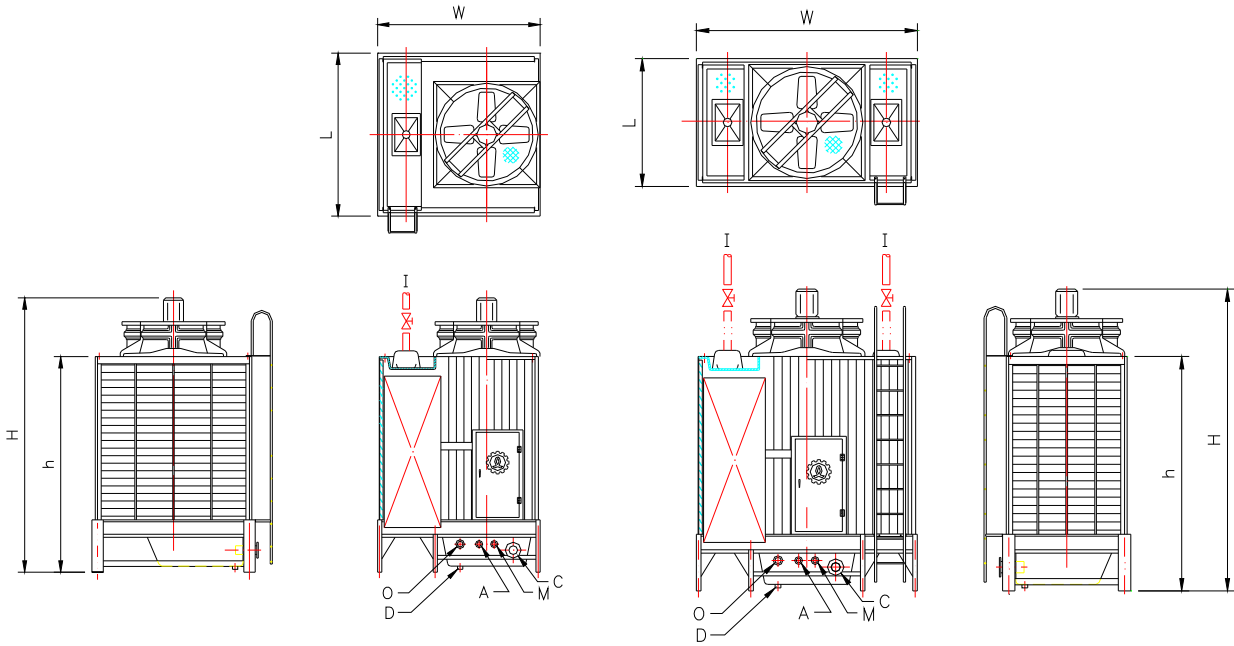

R-LC-01004~01007

R-LC-02008~02010

Tower Model R-LC-	Nominal Ton*1	Nominal Water Flow (L/S)	Dimensions (mm)				Fan Dia. (mm)	Fan Motor (HP)
			Width	Length	Height			
			W	L	h	H		
01004	33	7.2	2045	1555	2850	3515	970	1x1
01005	37	8	2045	1755	2850	3515	970	1x1
01006	46	10	2145	1955	2850	3625	1170	1 1/2x1
01007	54	11.7	2145	2155	2850	3625	1170	1 1/2x1
02008	60	13	2680	1555	2850	3670	1170	2x1
02010	72	15.6	2680	1755	2850	3670	1300	2x1
05012	93	20.2	2880	1955	2850	3710	1500	5x1
05015	114	24.7	3080	2360	2850	3710	1700	5x1
07017	130	28.2	3080	2360	2850	3710	1700	7 1/2x1
07020	152	32.9	3180	2560	2850	3730	1800	7 1/2x1
07022	171	37.1	3380	2660	2850	3730	2000	7 1/2x1
10025	187	40.5	3380	2960	2850	3730	2000	10x1
10030	246	53.3	4380	3570	3300	4760	2970	10x1
10035	271	58.7	4380	3770	3300	4760	2970	10x1
15040	297	64.4	4780	4170	3300	5025	3380	15x1

1. Nominal Tons are defined as the capacity that can deal with 13 lpm of water per ton, cooled from 37°C to 32°C with a 27°C entering wet bulb temperature.

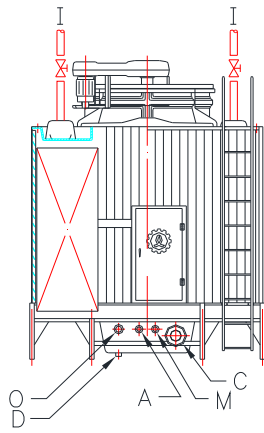
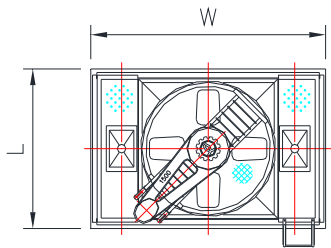

R-LC-05012~10025

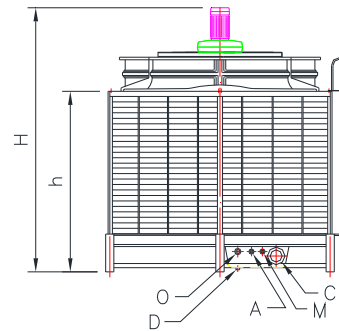
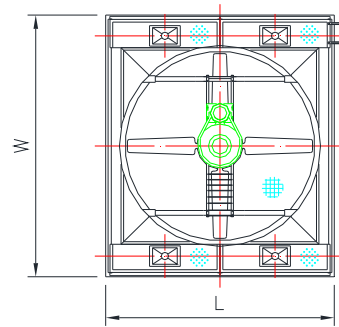

R-LC-10030~15040

Tower Model R-LC-	Pipe Connections						Approximate		Tower Head* 2 (M)
	Inlet	Outlet	Drain	Over Flow	Auto Filler	Quick Filler	Dry Wt.(kg)	Operating Wt.(kg)	
	(I)	(C)	(D)	(O)	(A)	(M)			
01004	3B(80A)×1	3B(80A)×1	2B(50A)×1	2B(50A)×1	3/4B(20A)×1	3/4B(20A)×1	430	1150	3.5
01005	3B(80A)×1	3B(80A)×1	2B(50A)×1	2B(50A)×1	3/4B(20A)×1	3/4B(20A)×1	480	1320	3.5
01006	4B(100A)×1	4B(100A)×1	2B(50A)×1	2B(50A)×1	3/4B(20A)×1	3/4B(20A)×1	540	1520	3.5
01007	4B(100A)×1	4B(100A)×1	2B(50A)×1	2B(50A)×1	3/4B(20A)×1	3/4B(20A)×1	620	1780	3.5
02008	3B(80A)×2	4B(100A)×1	2B(50A)×1	2B(50A)×1	3/4B(20A)×1	3/4B(20A)×1	710	1940	3.7
02010	3B(80A)×2	5B(125A)×1	2B(50A)×1	2B(50A)×1	1B(25A)×1	1B(25A)×1	750	2050	3.7
05012	4B(100A)×2	5B(125A)×1	2B(50A)×1	2B(50A)×1	1B(25A)×1	1B(25A)×1	800	2220	3.7
05015	4B(100A)×2	6B(150A)×1	2B(50A)×1	2B(50A)×1	1B(25A)×1	1B(25A)×1	940	2640	3.7
07017	5B(125A)×2	6B(150A)×1	2B(50A)×1	2B(50A)×1	1B(25A)×1	1B(25A)×1	970	2670	3.8
07020	5B(125A)×2	8B(200A)×1	2B(50A)×1	2B(50A)×1	1 1/4B(32A)×1	1 1/4B(32A)×1	1030	2830	3.8
07022	5B(125A)×2	8B(200A)×1	2B(50A)×1	2B(50A)×1	1 1/4B(32A)×1	1 1/4B(32A)×1	1120	3170	3.8
10025	5B(125A)×2	8B(200A)×1	2B(50A)×1	2B(50A)×1	1 1/4B(32A)×1	1 1/4B(32A)×1	1200	3370	3.8
10030	5B(125A)×4	8B(200A)×1	2B(50A)×1	2B(50A)×1	1 1/4B(32A)×1	1 1/4B(32A)×1	1660	3980	3.9
10035	5B(125A)×4	8B(200A)×1	2B(50A)×1	2B(50A)×1	1 1/4B(32A)×1	1 1/4B(32A)×1	1850	4640	3.9
15040	5B(125A)×4	8B(200A)×1	2B(50A)×1	2B(50A)×1	1 1/4B(32A)×1	1 1/4B(32A)×1	1990	5510	3.9

2. Total pump head required for cooling water circulation pump is the sum of condenser water pressure drop, piping friction loss and tower head.

3. All dimensions are in millimeters. Weights are in kilograms.

4. Multiple cell models of the single cell models above are also available but not listed. For more information, please Contact your local supplier or distributor.

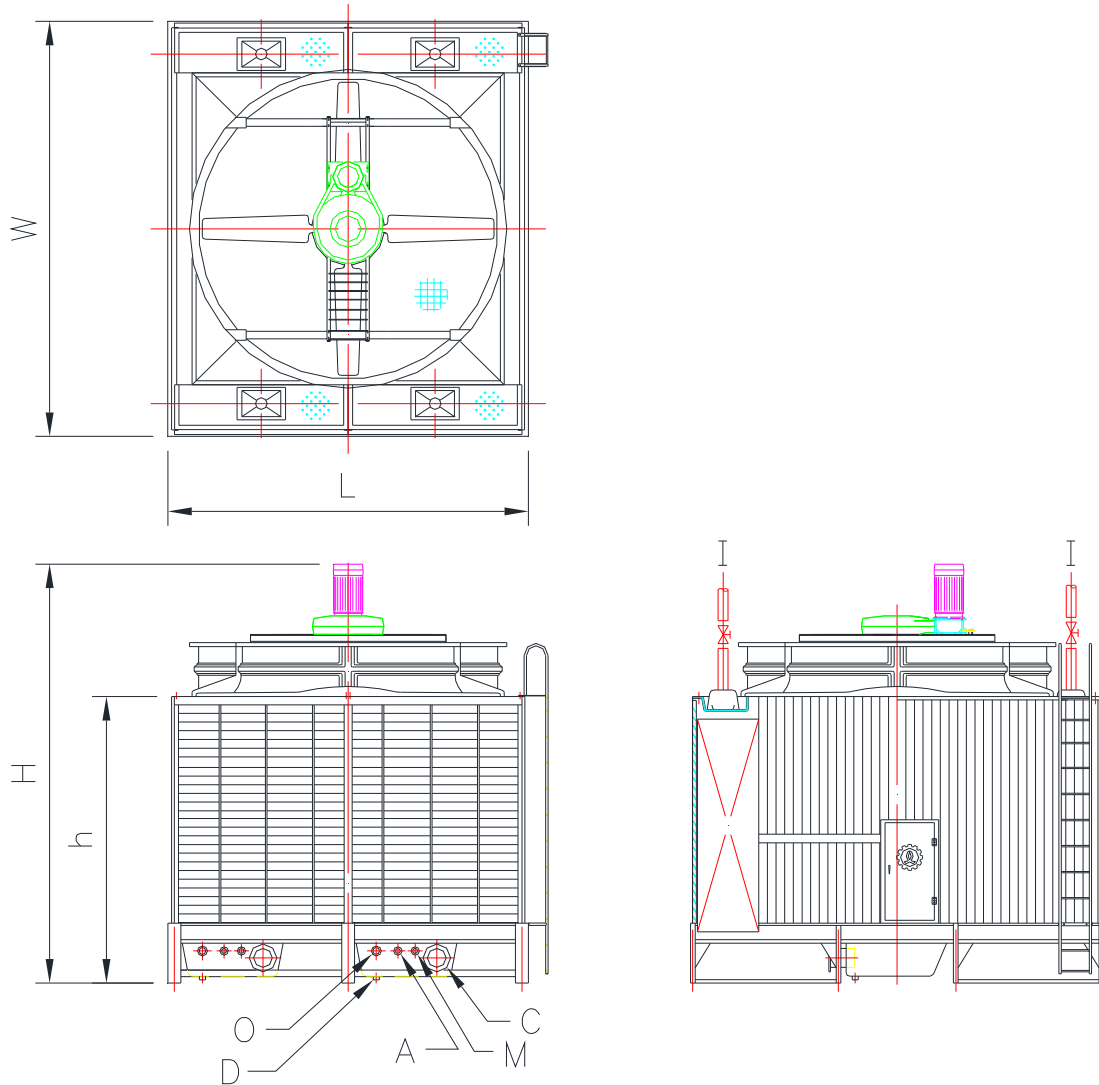

R-LC-15045~15050

Tower Model R-LC-	Nominal Ton*1	Nominal Water Flow (L/S)	Dimensions (mm)				Fan Dia. (mm)	Fan Motor (HP)
			Width	Length	Height			
			W	L	h	H		
15045	329	71.3	5380	4170	3300	5025	3380	15 x 1
15050	433	93.8	5380	4370	3700	5425	3380	15 x 1
20060	475	102.9	5580	5170	3700	5535	3580	20 x 1
20070	493	106.8	5580	5770	3700	5535	3580	20 x 1
30080	639	138.5	6280	5770	4200	6270	4250	30 x 1
30090	669	145	6280	6370	4200	6270	4250	30x 1
30100	774	167.7	6280	7170	4200	6270	4250	30 x 1

1. Nominal Tons are defined as the capacity that can deal with 13 lpm of water per ton, cooled from 37°C to 32°C with a 27°C entering wet bulb temperature.

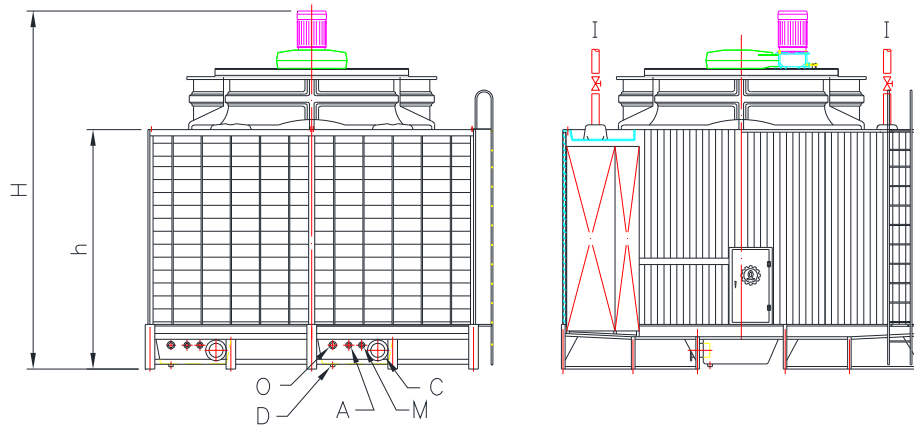
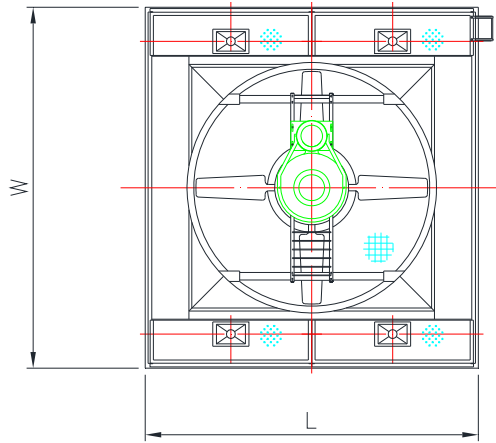

R-LC-20060~30100

Tower Model R-LC-	Pipe Connections						Approximate		Tower Head*2 (M)
	Inlet	Outlet	Drain	Over Flow	Auto Filler	Quick Filler	Dry Wt.(kg)	Operating Wt.(kg)	
	(I)	(C)	(D)	(O)	(A)	(M)			
15045	5B(125A)x4	8B(200A)x2	2B(50A)x2	2B(50A)x2	1 1/4B(32A)x2	1 1/4B(32A)x2	2290	6420	3.9
15050	5B(125A)x4	8B(200A)x2	2B(50A)x2	2B(50A)x2	1 1/4B(32A)x2	1 1/4B(32A)x2	2520	6930	4.3
20060	6B(150A)x4	8B(200A)x2	2B(50A)x2	2B(50A)x2	1 1/4B(32A)x2	1 1/4B(32A)x2	4200	10500	4.3
20070	6B(150A)x4	8B(200A)x2	2B(50A)x2	2B(50A)x2	1 1/4B(32A)x2	1 1/4B(32A)x2	4400	11400	4.3
30080	6B(150A)x4	10B(250A)x2	2B(50A) x2	2B(50A) x2	2B(50A) x2	2B(50A) x2	4900	12800	4.7
30090	8B(200A)x4	10B(250A)x2	2B(50A) x2	2B(50A) x2	2B(50A) x2	2B(50A) x2	5300	14000	4.7
30100	8B(200A)x4	10B(250A)x2	2B(50A) x2	2B(50A) x2	2B(50A) x2	2B(50A) x2	5800	15400	4.7

2.Total pump head required for cooling water circulation pump is the sum of condenser water pressure drop, piping friction loss and tower head.

3. All dimensions are in millimeters. Weights are in kilograms.

4. Multiple cell models of the single cell models above are also available but not listed. For more information, please Contact your local supplier or distributor.

STD-201RS Table 3a - IP Units - Cooling Towers (CT)

Condition Reference #	1	2	3	4	5	6	7	8	9	10
Wet Bulb °F	50	50	50	50	50	55	55	55	55	55
Range °F	10	10	10	15	15	10	10	10	15	15
Approach °F	7	10	12	7	12	7	10	12	7	12
Inlet Water Temperature °F	67	70	72	72	77	72	75	77	77	82
Outlet Water Temperature °F	57	60	62	57	62	62	65	67	62	67
	GPM									
R-LC-01004	42.6	57.1	67.4	33.7	51.5	47.4	63.4	74.8	37.5	57.4
R-LC-01005	48.3	64.6	76	38.3	58.3	53.6	71.6	84.3	42.6	64.8
R-LC-01006	50.8	71.7	86.8	38.3	63.3	57.5	80.9	98	43.5	71.7
R-LC-01007	59.3	83.8	101.5	44.6	74	67.2	94.6	114.6	50.7	84
R-LC-02008	84.6	110.5	128.4	68.6	100.6	93.1	121.4	141.3	75.5	111
R-LC-02010	95.3	126.6	148.5	76.2	114.8	105.7	140.2	164.5	84.6	127.6
R-LC-05012	111.7	153.1	182.6	86.5	137	125.2	171.3	204.4	97.3	153.9
R-LC-05015	140.1	190.4	225.9	109.6	171.3	156.8	212.6	252.4	123	192.1
R-LC-07017	157.9	215.7	256.8	122.8	193.3	176.8	241.1	287.1	137.8	216.8
R-LC-07020	186.7	254.2	302	145.6	228	208.8	283.7	337.3	163.3	255.5
R-LC-07022	210.4	286.6	340.6	164	256.8	235.2	319.7	380.2	183.7	287.5
R-LC-10025	207.1	291.7	352.5	156.5	258.3	234.6	329.3	398	177.9	293
R-LC-10030	299.9	410.1	488.4	232.8	366.5	335.5	457.8	545.6	261	410.6
R-LC-10035	354.8	474.1	557.7	281.5	427.9	393.7	525.3	618.5	312.9	475.7
R-LC-15040	399.7	530	620.9	319.2	479.5	442	585.4	686.5	353.5	531.2
R-LC-15045	384.3	531.5	636.3	295.5	474.4	432.7	596.7	714.6	333.8	534.9
R-LC-15050	594.3	778.6	906.6	482	711.6	656.7	859.3	1001.6	533.4	787.9
R-LC-20060	665.3	865.5	1004.2	543.6	793.9	733.6	953.3	1107.2	600.2	877.1
R-LC-20070	697	905.4	1049.6	569.7	829.9	767.4	995.9	1155.8	628.1	915.6
R-LC-30080	891.3	1162.1	1349.9	726.2	1064	983	1280.3	1488.7	802	1175.8
R-LC-30090	934.8	1219.2	1416.3	761.1	1115.4	1030.6	1342.6	1561.3	840.2	1232.1
R-LC-30100	1051.5	1385.5	1618.1	846.8	1260.6	1162.6	1529.9	1788.5	937.6	1396.3

STD-201RS Table 3b - SI Units - Cooling Towers (CT)

Condition Reference #	1	2	3	4	5	6	7	8	9	10
Wet Bulb °C	10	10	10	10	10	13	13	13	13	13
Range °C	6	6	6	8	8	6	6	6	8	8
Approach °C	4	6	7	4	7	4	6	7	4	7
Inlet Water Temperature °C	20	22	23	22	25	23	25	26	25	28
Outlet Water Temperature °C	14	16	17	14	17	17	19	20	17	20
	L/S									
R-LC-01004	2.6	3.7	4.2	2.2	3.5	2.9	4.1	4.7	2.5	3.9
R-LC-01005	3	4.1	4.7	2.5	3.9	3.3	4.6	5.3	2.8	4.4
R-LC-01006	3.1	4.6	5.4	2.5	4.3	3.6	5.3	6.2	2.9	5
R-LC-01007	3.6	5.4	6.3	3	5.1	4.1	6.2	7.3	3.4	5.8
R-LC-02008	5.2	7.1	8	4.5	6.8	5.8	7.8	8.9	5	7.5
R-LC-02010	5.9	8.1	9.3	5	7.7	6.6	9.1	10.4	5.6	8.7
R-LC-05012	6.8	9.8	11.4	5.7	9.3	7.8	11.1	12.9	6.5	10.6
R-LC-05015	8.6	12.2	14.1	7.2	11.6	9.7	13.8	16	8.2	13.2
R-LC-07017	9.7	13.8	16	8.1	13.1	10.9	15.6	18.2	9.2	14.9
R-LC-07020	11.5	16.3	18.9	9.6	15.4	12.9	18.4	21.3	10.9	17.5
R-LC-07022	12.9	18.4	21.3	10.8	17.4	14.6	20.7	24	12.2	19.7
R-LC-10025	12.7	18.7	22	10.4	17.6	14.5	21.4	25.2	11.9	20.3
R-LC-10030	18.4	26.3	30.5	15.4	24.9	20.8	29.7	34.5	17.4	28.2
R-LC-10035	21.8	30.3	34.9	18.5	28.9	24.4	34	39.1	20.7	32.4
R-LC-15040	24.6	33.9	38.8	21	32.3	27.4	37.9	43.4	23.4	36.1
R-LC-15045	23.5	34.1	39.7	19.5	32.3	26.8	38.8	45.2	22.3	36.8
R-LC-15050	36.6	49.8	56.7	31.6	47.8	40.8	55.6	63.4	35.2	53.4
R-LC-20060	41	55.4	62.9	35.6	53.2	45.6	61.7	70.1	39.6	59.4
R-LC-20070	43	57.9	65.7	37.3	55.6	47.7	64.4	73.2	41.4	61.9
R-LC-30080	54.9	74.3	84.5	47.5	71.3	61.1	82.8	94.2	52.9	79.6
R-LC-30090	57.6	78	88.6	49.8	74.8	64.1	86.9	98.8	55.4	83.5
R-LC-30100	64.7	88.6	101.2	55.5	84.7	72.2	99	113.2	62	94.8

STD-201RS Table 3a - IP Units - Cooling Towers (CT)

Condition Reference #	11	12	13	14	15	16	17	18	19	20
Wet Bulb °F	60	60	60	60	60	65	65	65	65	65
Range °F	10	10	10	15	15	10	10	10	15	15
Approach °F	7	10	12	7	12	7	10	12	7	12
Inlet Water Temperature °F	77	80	82	82	87	82	85	87	87	92
Outlet Water Temperature °F	67	70	72	67	72	72	75	77	72	77
	GPM									
R-LC-01004	52.7	70.9	83.7	41.9	64.3	59.2	79.7	94	47.1	72.4
R-LC-01005	59.6	79.9	94.2	47.5	72.5	66.8	89.7	105.6	53.3	81.6
R-LC-01006	65.2	92	111.5	49.5	81.9	74.6	105.4	127.4	56.7	94
R-LC-01007	76.2	107.8	130.5	57.8	95.9	87.3	123.5	149.3	66.4	110.2
R-LC-02008	102.6	134.4	156.5	83.3	123	113.9	149.5	174	92.6	137
R-LC-02010	117.4	156.3	183.6	94.2	142.6	131.4	175.3	205.7	105.6	160.1
R-LC-05012	140.7	193.1	230.5	109.7	174.1	159.4	219.1	261.1	124.6	197.9
R-LC-05015	175.8	239.1	283.9	138.4	216.7	198.7	270.6	320.8	156.8	245.8
R-LC-07017	198.3	271.4	323.3	155	244.8	224.4	307.4	365.8	175.8	277.9
R-LC-07020	233.8	318.9	379.3	183.4	288	264.2	360.8	428.6	207.6	326.5
R-LC-07022	263.2	359.3	427.4	206.1	323.9	297.2	406.2	482.8	233.2	367
R-LC-10025	266.1	374.7	452.7	202.7	334.6	304.8	429	517.3	232.9	384.2
R-LC-10030	375.7	514.9	613.9	293.1	463.1	424.7	582.7	694	331.8	525
R-LC-10035	437.4	586.1	690.6	348.3	531.9	490.1	657.8	774.6	390.8	597.9
R-LC-15040	489.4	650.9	764.1	392.1	592	546.5	728.2	854.2	438.3	663
R-LC-15045	487.7	674.8	808.2	377.7	607.1	554.9	768	918.3	430.9	692.7
R-LC-15050	726.6	954.6	1113.5	591.5	877.3	810.4	1066.5	1243.3	660.5	981.6
R-LC-20060	809.9	1056.8	1228.3	663.9	974.4	901.2	1178	1368.6	739.5	1087.6
R-LC-20070	846.1	1102.5	1280.6	693.7	1015.7	940.2	1227.3	1425	771.4	1132
R-LC-30080	1085.6	1419.6	1652	887.3	1306.6	1208.3	1583	1841.2	988.6	1458.9
R-LC-30090	1137.8	1488.2	1732.1	929.1	1368.6	1265.9	1658.9	1929.8	1034.8	1527.5
R-LC-30100	1287.1	1700.7	1989.7	1040.1	1555.7	1436.5	1901.5	2223.3	1162.1	1741.8

STD-201RS Table 3b - SI Units - Cooling Towers (CT)

Condition Reference #	11	12	13	14	15	16	17	18	19	20
Wet Bulb °C	16	16	16	16	16	18	18	18	18	18
Range °C	6	6	6	8	8	6	6	6	8	8
Approach °C	4	6	7	4	7	4	6	7	4	7
Inlet Water Temperature °C	26	28	29	28	31	28	30	31	30	33
Outlet Water Temperature °C	20	22	23	20	23	22	24	25	22	25
	L/S									
R-LC-01004	3.3	4.6	5.3	2.8	4.4	3.6	5	5.8	3.1	4.8
R-LC-01005	3.7	5.2	6	3.2	5	4.1	5.7	6.5	3.5	5.4
R-LC-01006	4.1	6.1	7.1	3.4	5.7	4.5	6.7	7.8	3.7	6.3
R-LC-01007	4.8	7.1	8.3	3.9	6.7	5.3	7.8	9.2	4.3	7.4
R-LC-02008	6.4	8.8	10	5.6	8.4	6.9	9.5	10.8	6	9.1
R-LC-02010	7.4	10.2	11.7	6.3	9.8	8	11.1	12.7	6.8	10.6
R-LC-05012	8.8	12.7	14.7	7.4	12.1	9.7	13.9	16.1	8.1	13.2
R-LC-05015	11	15.7	18.2	9.3	15	12.1	17.1	19.8	10.2	16.4
R-LC-07017	12.4	17.8	20.7	10.5	17	13.6	19.4	22.6	11.4	18.6
R-LC-07020	14.7	20.9	24.2	12.4	19.9	16	22.8	26.5	13.5	21.8
R-LC-07022	16.5	23.5	27.3	13.9	22.4	18	25.7	29.8	15.2	24.5
R-LC-10025	16.7	24.6	29	13.8	23.4	18.4	27.1	31.9	15.2	25.8
R-LC-10030	23.6	33.7	39.2	19.8	32.1	25.7	36.8	42.8	21.6	35.1
R-LC-10035	27.5	38.3	44.1	23.4	36.6	29.8	41.6	47.9	25.4	39.8
R-LC-15040	30.7	42.5	48.8	26.3	40.7	33.2	46	52.8	28.4	44.1
R-LC-15045	30.6	44.3	51.7	25.5	42.2	33.6	48.6	56.7	28	46.3
R-LC-15050	45.7	62.4	71.2	39.5	60	49.4	67.5	77	42.7	65
R-LC-20060	51	69	78.5	44.3	66.5	55	74.5	84.8	47.8	71.9
R-LC-20070	53.2	72	81.8	46.2	69.3	57.4	77.6	88.3	49.8	74.9
R-LC-30080	68.3	92.7	105.5	59.2	89.3	73.7	100.1	114.1	63.9	96.6
R-LC-30090	71.5	97.2	110.6	62	93.5	77.2	104.9	119.5	66.9	101.1
R-LC-30100	80.9	111.1	127.1	69.5	106.6	87.5	120.3	137.6	75.2	115.5

STD-201RS Table 3a - IP Units - Cooling Towers (CT)

Condition Reference #	21	22	23	24	25	26	27	28	29	30
Wet Bulb °F	70	70	70	70	70	75	75	75	75	75
Range °F	10	10	10	15	15	10	10	10	15	15
Approach °F	7	10	12	7	12	7	10	12	7	12
Inlet Water Temperature °F	87	90	92	92	97	92	95	97	97	102
Outlet Water Temperature °F	77	80	82	77	82	82	85	87	82	87
	GPM									
R-LC-01004	66.6	89.7	106	53	81.7	75.1	100.9	119.6	59.9	92.3
R-LC-01005	75.1	100.8	118.9	60	91.9	84.6	113.3	134.1	67.7	103.8
R-LC-01006	85.5	120.7	146.1	65.3	108	98.4	138.2	167.8	75.3	124.4
R-LC-01007	100.2	141.6	171.3	76.6	126.8	115.5	162.2	196.8	88.4	146.3
R-LC-02008	126.7	166.5	194.2	103.2	152.8	141.4	185.4	216.9	115.2	170.9
R-LC-02010	147.4	196.7	231.3	118.7	180.1	166	220.8	260.5	133.7	203.2
R-LC-05012	181	248.7	296.7	141.9	225.2	206.3	282.2	337.7	162	257.1
R-LC-05015	225.1	306.4	363.8	178.2	279.1	256	346.9	413	203	317.8
R-LC-07017	254.4	348.4	415.2	199.9	315.9	289.5	394.9	471.9	227.8	360
R-LC-07020	299.1	408.4	485.9	235.7	370.6	339.9	462.3	551.7	268.1	421.7
R-LC-07022	336.3	459.7	547.2	264.5	416.3	382	520.1	621.1	300.8	473.6
R-LC-10025	349.6	491.4	593	268.3	441.7	402.5	562.6	680.6	309.7	509.1
R-LC-10030	480.8	660	787.4	376.6	596.1	546.7	747.4	894.5	428.5	678.7
R-LC-10035	550.2	739	871.7	439.6	673.1	620	830.1	982.5	495.5	759.8
R-LC-15040	611.2	815.2	958.1	491	743.7	686.3	912.7	1076.3	551.4	836.4
R-LC-15045	632.3	874.5	1046.8	492.9	791.3	723.4	995.5	1194.7	565	906.3
R-LC-15050	905.5	1192.6	1392.7	739.3	1099.9	1015.4	1333.7	1562.4	829.3	1235.6
R-LC-20060	1004.5	1314.3	1529.7	825.6	1215.7	1123.7	1466.5	1712.1	923.7	1362.4
R-LC-20070	1046.4	1367.5	1590.6	859.8	1263.5	1168.8	1523.8	1777.9	960.4	1413.8
R-LC-30080	1347.2	1766.7	2058.6	1104	1631.3	1507.6	1971.9	2304.9	1235.6	1828.6
R-LC-30090	1410.8	1850.7	2156.8	1155.1	1707.3	1578.2	2064.9	2414	1292.2	1913
R-LC-30100	1606.1	2127.8	2492.4	1301.7	1953	1802.5	2381.2	2798	1461.1	2195.4

STD-201RS Table 3b - SI Units - Cooling Towers (CT)

Condition Reference #	21	22	23	24	25	26	27	28	29	30
Wet Bulb °C	21	21	21	21	21	24	24	24	24	24
Range °C	6	6	6	8	8	6	6	6	8	8
Approach °C	4	6	7	4	7	4	6	7	4	7
Inlet Water Temperature °C	31	33	34	33	36	34	36	37	36	39
Outlet Water Temperature °C	25	27	28	25	28	28	30	31	28	31
	L/S									
R-LC-01004	4.1	5.7	6.6	3.5	5.5	4.6	6.5	7.5	4	6.3
R-LC-01005	4.6	6.4	7.4	3.9	6.2	5.2	7.3	8.4	4.5	7
R-LC-01006	5.2	7.7	9.1	4.3	7.3	6.1	9	10.6	5	8.5
R-LC-01007	6.1	9.1	10.7	5	8.6	7.1	10.5	12.4	5.9	10
R-LC-02008	7.8	10.6	12.1	6.7	10.2	8.8	12	13.7	7.6	11.5
R-LC-02010	9	12.6	14.4	7.8	12.1	10.3	14.3	16.4	8.8	13.8
R-LC-05012	11.1	15.9	18.5	9.3	15.2	12.7	18.3	21.3	10.7	17.5
R-LC-05015	13.8	19.6	22.7	11.7	18.8	15.8	22.5	26	13.4	21.6
R-LC-07017	15.6	22.3	25.9	13.1	21.3	17.9	25.6	29.7	15.1	24.5
R-LC-07020	18.3	26.1	30.3	15.5	25	21	29.9	34.7	17.8	28.7
R-LC-07022	20.6	29.4	34.1	17.3	28.1	23.6	33.7	39.1	19.9	32.2
R-LC-10025	21.3	31.4	36.9	17.7	29.9	24.8	36.5	42.8	20.6	34.9
R-LC-10030	29.4	42.1	49	24.7	40.2	33.7	48.4	56.3	28.4	46.3
R-LC-10035	33.7	47.2	54.3	28.8	45.2	38.3	53.7	61.8	32.7	51.5
R-LC-15040	37.5	52	59.7	32.1	49.9	42.5	59	67.7	36.4	56.6
R-LC-15045	38.7	55.9	65.2	32.4	53.4	44.7	64.5	75.2	37.5	61.8
R-LC-15050	55.7	76.1	87	48.2	73.5	63	86.2	98.5	54.5	83.3
R-LC-20060	61.8	83.9	95.5	53.8	81.1	69.7	94.7	107.9	60.7	91.7
R-LC-20070	64.4	87.3	99.3	56	84.3	72.5	98.4	112.1	63.1	95.2
R-LC-30080	82.9	112.8	128.5	71.9	108.9	93.5	127.4	145.3	81.2	123.2
R-LC-30090	86.8	118.1	134.7	75.3	114	97.9	133.4	152.1	84.9	128.9
R-LC-30100	98.7	135.8	155.5	84.9	130.7	111.6	153.9	176.2	96.2	148.3

STD-201RS Table 3a - IP Units - Cooling Towers (CT)

Condition Reference #	31	32	33	34	35	36	37	38	39	40
Wet Bulb °F	80	80	80	80	80	85	85	85	85	85
Range °F	10	10	10	15	15	10	10	10	15	15
Approach °F	7	10	12	7	12	7	10	12	7	12
Inlet Water Temperature °F	97	100	102	102	107	102	105	107	107	112
Outlet Water Temperature °F	87	90	92	87	92	92	95	97	92	97
	GPM									
R-LC-01004	85	114.2	135	67.9	104.5	96.1	129.6	153.3	76.9	118.9
R-LC-01005	95.5	128	151.2	76.5	117.2	107.9	145.1	171.3	86.6	133.2
R-LC-01006	113.4	159.2	192.6	87	143.4	130.8	183.9	222.3	100.7	166.3
R-LC-01007	133.3	186.9	225.9	102.4	168.7	153.8	216	260.9	118.7	195.8
R-LC-02008	158.1	207.5	242.3	128.8	191.2	176.9	232.9	272.1	144.3	215
R-LC-02010	187.2	249.1	293.2	151	229.2	211.2	282	331.9	170.7	260.1
R-LC-05012	235.5	321.9	384.1	185.3	293.5	268.9	368.4	439.4	212.3	337
R-LC-05015	291.4	394.7	468.6	231.7	362	332	450.5	534.7	264.8	414.5
R-LC-07017	329.9	449.9	536.2	260.2	410.4	376.2	514.3	612.7	297.6	470.5
R-LC-07020	386.8	526	626	305.8	480.1	440.4	600.5	714.5	349.2	549.7
R-LC-07022	434.5	591.7	704.7	342.8	538.9	494.5	675.3	804.2	391.2	616.8
R-LC-10025	464.1	647.4	780.3	358.4	586.6	535.1	747.4	899.7	415.1	679.9
R-LC-10030	622.4	851	1015.8	488.8	772.9	709	972.3	1160.5	558.3	885.6
R-LC-10035	699.7	937.4	1107	560	857.9	790.2	1061.9	1254.4	633.5	974.2
R-LC-15040	771.7	1027.1	1208.7	620.6	941	868.3	1159.5	1365	699.3	1064.6
R-LC-15045	828.7	1139.1	1362.5	649.3	1038.1	949.5	1307.4	1562.7	746.8	1195.9
R-LC-15050	1140.3	1498.7	1752.3	932.5	1388.5	1281.4	1689.4	1975.9	1049.7	1568.8
R-LC-20060	1258.8	1644.1	1916	1035.8	1527.4	1411.1	1848.9	2155.5	1162.9	1721.3
R-LC-20070	1307.4	1706	1987	1075.2	1582.6	1463.4	1915.7	2232.4	1205.1	1780.8
R-LC-30080	1689.4	2211.5	2580.2	1386.1	2050.7	1894.5	2487.8	2903.7	1556.6	2311.8
R-LC-30090	1767.9	2315	2701.4	1448.9	2144.4	1981.6	2603.3	3039.1	1626.4	2416.5
R-LC-30100	2025.8	2678	3140.5	1644.1	2468.9	2278.2	3021.3	3544.3	1852	2791.7

STD-201RS Table 3b - SI Units - Cooling Towers (CT)

Condition Reference #	31	32	33	34	35	36	37	38	39	40
Wet Bulb °C	27	27	27	27	27	29	29	29	29	29
Range °C	6	6	6	8	8	6	6	6	8	8
Approach °C	4	6	7	4	7	4	6	7	4	7
Inlet Water Temperature °C	37	39	40	39	42	39	41	42	41	44
Outlet Water Temperature °C	31	33	34	31	34	33	35	36	33	36
	L/S									
R-LC-01004	5.3	7.5	8.6	4.5	7.2	5.8	8.2	9.4	5	7.9
R-LC-01005	6	8.4	9.6	5.1	8	6.5	9.1	10.5	5.6	8.8
R-LC-01006	7.1	10.4	12.3	5.9	10	7.8	11.6	13.6	6.5	11.1
R-LC-01007	8.3	12.3	14.4	6.9	11.7	9.2	13.6	16	7.7	13
R-LC-02008	9.9	13.5	15.4	8.6	13	10.7	14.7	16.8	9.3	14.2
R-LC-02010	11.7	16.3	18.7	10.1	15.7	12.8	17.8	20.4	11	17.2
R-LC-05012	14.7	21.1	24.5	12.4	20.3	16.2	23.2	27	13.7	22.3
R-LC-05015	18.2	25.8	29.9	15.5	24.9	20	28.4	32.9	17.1	27.4
R-LC-07017	20.6	29.5	34.2	17.4	28.3	22.7	32.4	37.7	19.2	31.2
R-LC-07020	24.2	34.4	40	20.5	33.1	26.6	37.8	43.9	22.5	36.4
R-LC-07022	27.1	38.7	45	22.9	37.1	29.8	42.6	49.4	25.2	40.9
R-LC-10025	29	42.5	49.9	24.1	40.7	32.1	47.1	55.2	26.8	45.2
R-LC-10030	38.8	55.7	64.8	32.7	53.3	42.7	61.3	71.3	36	58.8
R-LC-10035	43.7	61.2	70.6	37.3	58.9	47.8	66.9	77.2	40.8	64.4
R-LC-15040	48.2	67	77	41.3	64.4	52.5	73.1	84	45.1	70.3
R-LC-15045	51.8	74.7	87	43.6	71.7	57.2	82.4	96	48.2	79.3
R-LC-15050	71.4	97.8	111.8	61.9	94.7	77.7	106.6	121.9	67.5	103.3
R-LC-20060	78.8	107.2	122.3	68.7	104	85.7	116.6	133	74.7	113.2
R-LC-20070	81.9	111.2	126.7	71.3	107.7	88.9	120.8	137.8	77.4	117.2
R-LC-30080	105.8	144.2	164.6	91.9	139.7	115	156.9	179.1	100	152.2
R-LC-30090	110.7	151	172.3	96.1	146.1	120.3	164.2	187.5	104.5	159.1
R-LC-30100	126.7	174.8	200.3	109.3	168.7	138	190.5	218.4	119.1	184.1

STD-201RS Table 3a - IP Units - Cooling Towers (CT)

Condition Reference #	41	42	43	44	45		46	47	48	49
Wet Bulb °F	90	90	90	90	90		69.8	78	80.6	82.4
Range °F	10	10	10	15	15		9	10	9	9
Approach °F	7	10	12	7	12		10.8	7	9	7.2
Inlet Water Temperature °F	107	110	112	112	117		89.6	95	98.6	98.6
Outlet Water Temperature °F	97	100	102	97	102		80.6	85	89.6	89.6
	GPM									
R-LC-01004	109.1	147.3	174.3	87.5	135.3		102.7	80.6	113.3	98.3
R-LC-01005	122.4	164.7	194.6	98.4	151.4		115.3	90.7	127.1	110.3
R-LC-01006	151.4	212.8	257.2	117	192.8		141.1	106.8	158	134.2
R-LC-01007	178.2	250.1	301.8	138	227.2		165.3	125.4	185.5	157.7
R-LC-02008	198.5	261.9	306.2	162.2	241.9		188.6	150.8	206.1	180.6
R-LC-02010	239.1	319.7	376.5	193.7	295.2		224.2	177.8	247.3	215.5
R-LC-05012	308.1	422.3	503.6	244.1	387		286.9	222.6	319.4	274.9
R-LC-05015	379.4	515.1	611.2	303.6	474.8		351.8	275.8	391.5	338.7
R-LC-07017	430.5	588.9	701.5	341.6	539.6		401.6	312.1	446.5	384.7
R-LC-07020	503.3	686.8	817.2	400.2	629.6		470.1	366.1	522	450.4
R-LC-07022	564.8	772.1	919.7	448	706.2		529.6	411.3	587.3	506.1
R-LC-10025	619	864	1039.2	482.4	787.9		572.3	436.8	642.2	547.8
R-LC-10030	810.7	1112.9	1328.6	640	1014.9		762	588.9	844.9	726.5
R-LC-10035	895.4	1205.4	1424.5	719.3	1106.7		845.1	664.5	930.7	808.1
R-LC-15040	980.2	1311.4	1544.8	790.8	1204.9		929.7	734	1020	888
R-LC-15045	1091.7	1502.9	1795.5	862.1	1377.7		1011.3	782.1	1129.9	970.6
R-LC-15050	1444.7	1907.8	2232.5	1185.5	1773.2		1350.6	1085.4	1487.1	1304.4
R-LC-20060	1586.8	2082.9	2429.8	1309.7	1940.6		1484	1199.4	1631.4	1435.3
R-LC-20070	1643.1	2155.1	2513	1355	2004.6		1543.9	1246.5	1693.2	1489.7
R-LC-30080	2131.1	2803.7	3274.4	1753.9	2607.3		1997.2	1609.4	2194.6	1928.4
R-LC-30090	2228.2	2932.8	3425.9	1831.6	2724.3		2092.9	1684.4	2297.6	2018.1
R-LC-30100	2570.4	3414.9	4008.2	2093.3	3157.9		2417.4	1927.4	2658.2	2323.8

STD-201RS Table 3b - SI Units - Cooling Towers (CT)

Condition Reference #	41	42	43	44	45		46	47	48	49
Wet Bulb °C	32.2	32.2	32.2	32.2	32.2		21	25.56	27	28
Range °C	6	6	6	8	8		5	5.56	5	5
Approach °C	4	6	7	4	7		6	3.89	5	4
Inlet Water Temperature °C	42.2	44.2	45.2	44.2	47.2		32	35.00	37	37
Outlet Water Temperature °C	36.2	38.2	39.2	36.2	39.2		27	29.44	32	32
	L/S									
R-LC-01004	6.7	9.5	10.9	5.7	9.1		6.5	5.1	7.2	6.2
R-LC-01005	7.5	10.6	12.2	6.5	10.2		7.3	5.7	8	7
R-LC-01006	9.3	13.7	16.1	7.7	13.1		8.9	6.7	10	8.5
R-LC-01007	10.9	16.1	18.9	9.1	15.4		10.4	7.9	11.7	10
R-LC-02008	12.3	16.8	19.2	10.6	16.2		11.9	9.5	13	11.4
R-LC-02010	14.7	20.5	23.6	12.7	19.9		14.1	11.2	15.6	13.6
R-LC-05012	19	27.1	31.6	16.1	26.2		18.1	14	20.2	17.3
R-LC-05015	23.4	33.1	38.3	20	32		22.2	17.4	24.7	21.4
R-LC-07017	26.5	37.8	44	22.5	36.5		25.3	19.7	28.2	24.3
R-LC-07020	31	44.1	51.2	26.3	42.6		29.7	23.1	32.9	28.4
R-LC-07022	34.8	49.6	57.6	29.5	47.8		33.4	25.9	37.1	31.9
R-LC-10025	38	55.6	65.1	31.8	53.5		36.1	27.6	40.5	34.6
R-LC-10030	49.9	71.5	83.2	42.1	68.7		48.1	37.1	53.3	45.8
R-LC-10035	55.2	77.4	89.3	47.2	74.6		53.3	41.9	58.7	51
R-LC-15040	60.4	84.1	96.8	51.9	81.1		58.6	46.3	64.4	56
R-LC-15045	67.2	96.6	112.6	56.8	93.3		63.8	49.3	71.3	61.2
R-LC-15050	89.2	122.5	140.1	77.5	118.9		85.2	68.5	93.8	82.3
R-LC-20060	98.1	133.7	152.5	85.6	130		93.6	75.7	102.9	90.5
R-LC-20070	101.5	138.3	157.7	88.5	134.3		97.4	78.6	106.8	94
R-LC-30080	131.7	179.9	205.5	114.6	174.8		126	101.5	138.5	121.7
R-LC-30090	137.7	188.2	215	119.7	182.6		132	106.3	145	127.3
R-LC-30100	158.6	219.1	251.4	137.1	212.2		152.5	121.6	167.7	146.6